

## VAG Valves and Process Automation for Biogas Plants

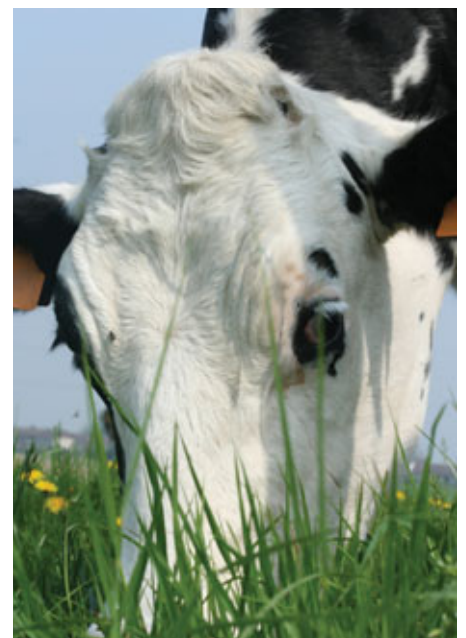

# As the source of energy of the future, biogas needs future-oriented valve solutions



## Hazards in biogas plants for valve technology

In today's modern biogas plants, output mainly depends on the accuracy and reliability of the process cycles, which are generally controlled by automatic and manual valves. This is why the operational safety, the reliability and the efficiency of a biogas plant depends on the working order of the used valves.

Biogas plants submit standard valve technology to a variety of hazards:

- Corrosion of aggressive media (e.g. liquid manure) or gas elements such as ammonia and hydrogen sulphide combined with an effect on operational safety and reliability
- Sedimentation caused by specific compositions of the liquid media and the resulting mechanical damage to sealants at relative movement
- Blockage caused by fibrous elements in the transported fermenting substrates affect the operation of the plant or even shut it down completely
- Surge protection in the case of disaster

# VAG ZETA® Knife Gate valve, the perfect fit for biogas plants

## The requirements:

- Suitable for solid media
- Long service life
- Low maintenance
- Low actuating forces
- Can be used as wafer-type gate valve and for end of line service
- Leak tight in both flow directions
- Can be installed in any position
- Approved by German Accident Prevention Regulations (UVV)
- Easy to automate

### Low risk of sedimentation means it's reliable

- Smooth flow passage
- Absence of problematic bottom pockets provide for a low blockage risk
- Unlimited tightness in both flow directions
- Wide sealing surface in lower passageway guarantees a safe sealing surface even at high lateral forces caused by inner pressure and axial ball bearing distortion
- Low risk of sedimentation and foreign matter does not impact the operational reliability
- Seal has a big elastomer volume, which guarantees high sealing reserves if the gasket is partially destroyed

- Chambered sealing profile provides for strong hold

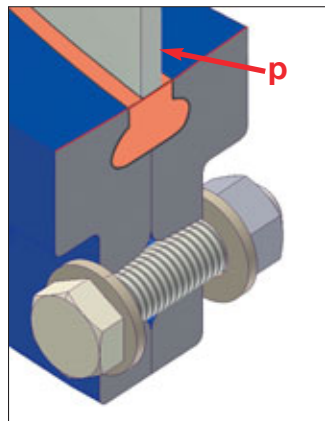

### Optimised storage prevents blockages

- Optimised side-guiding provides for high operational safety and reliability
- Flushing ports provide for safe shut-off without blockages
- Dirt particles and fibrous components are pushed out by the door and rinsed away by the gap flow
- Soft and elastic side-guiding improves the sealing function



### VAG's lateral sealing principle guarantees operational safety and service life

- VAG's scraper system removes sedimentation from the door every time it's operated
- VAG's scraper system reduces the wear and fouling of the lateral sealing system and increases the reliability
- High external pressure tightness is guaranteed by a special shaped lateral seal with double sealing surface
- Integrated PTFE sliding bars guide the door and guarantee sealing
- Maintenance friendly - Lateral seal can be adjusted during operation

- Lateral seal is easy to release without removing the valve from the pipeline

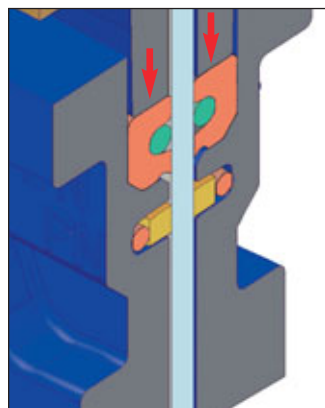

### Optimised internal body reduces the risk of sedimentation

- Optimised body shape combined with VAG's scraper system provides for a high level of safety against blockage and sedimentation

- High reliability even in the most difficult installation situations such as horizontal or suspended installation

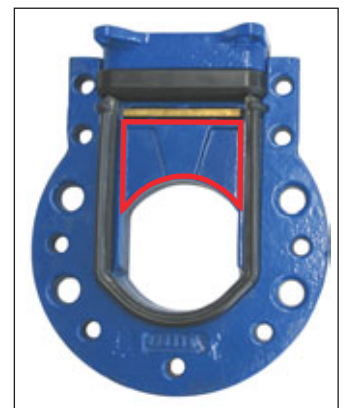
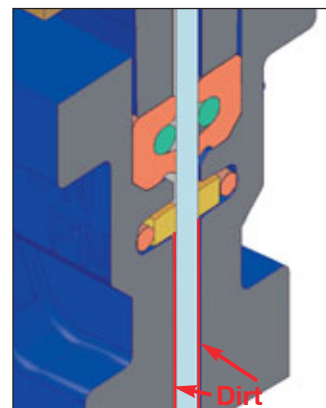

# Pneumatic process automation for biogas plants

- Safe operations
- Stable processes
- Optimal output
- High efficiency

## Control process in biogas plants

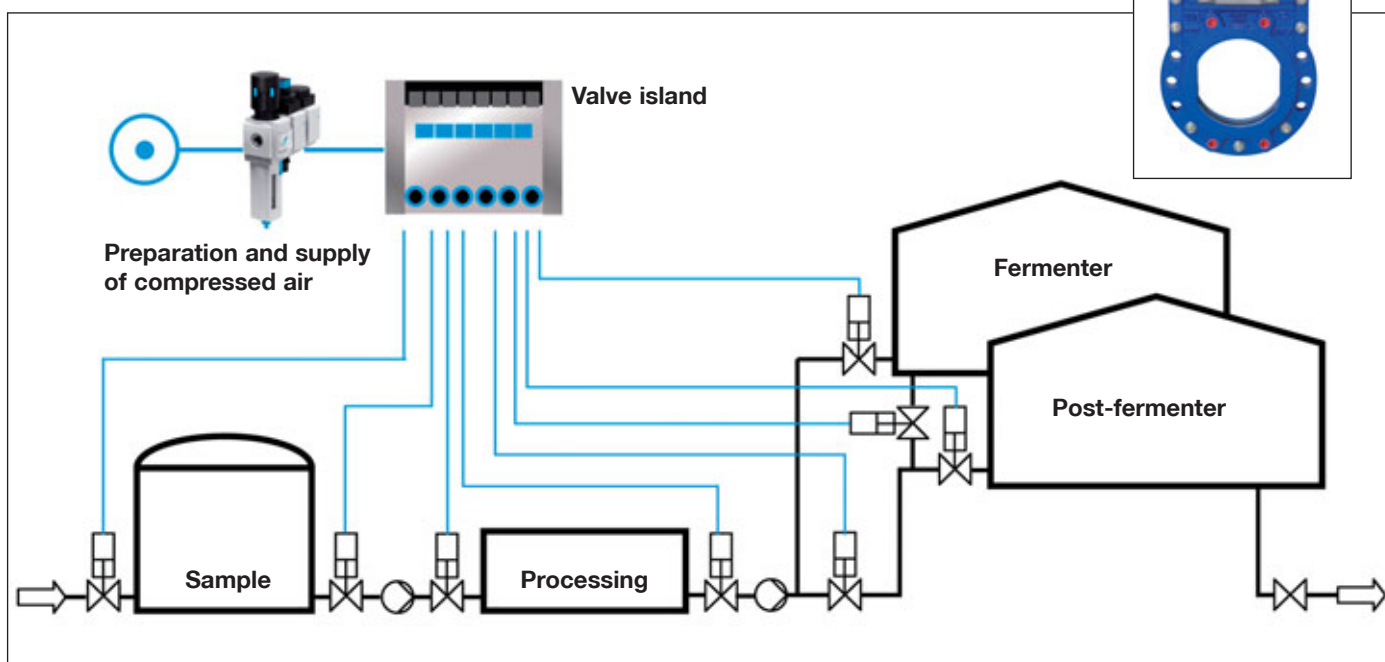

## Valves • Drive technology • Control Everything from a single source

- Affordable system solution
- Universal automation concept - no interface problems
- Robust and reliable components, technology that has been proven more than a thousand times
- High operational safety and long service life
- No additional costs when used in the explosive area
- High safety through defined function when the power fails
- Variable opening and closing times
- Compressed-air safety reserve provides 'second' energy



VAG-Armaturen GmbH  
Carl-Reuther-Str. 1  
68305 Mannheim  
Germany  
Phone +49 6 21 749-0  
Fax +49 6 21 749-2153  
info@vag-armaturen.com  
www.vag-armaturen.com